



EXCELÊNCIA EM USINAGEM
*Ferramentas de Corte, acessórios para
máquinas e instrumentos de medição.*

DISTRIBUIDOR AUTORIZADO DORMER PRAMET

☎ 47.3017-1921 | vendas@espacodasferramentas.com.br
📍 Rua Piratuba, 1646 - Bom Retiro, Joinville - SC, 89222-363

DORMER PRAMET

FERRAMENTAS ROTATIVAS, ESPECIALISTA EM METAL DURO



BROCAS DE AÇO RÁPIDO E METAL DURO

MODELO - PARALELA, LONGA, EXTRA LONGA, HASTE CÔNICA.



ALARGADORES

MODELO - MANUAL, MÁQUINA, HASTE CÔNICA, METAL DURO.



FRESAS DE AÇO RÁPIDO E METAL DURO

MODELO - RASGO, TOPO, CANAIS, DESBASTE, ACABAMENTO.



MACHOS

MODELO - MANUAL, MÁQUINA (HELICOIDAL, RETO, LAMINADOR).



COSSINETES

MODELO - SEXTAVADO (M, MF, UNF, UNC, BSW, BSP, BSF, NPT).



LIMAS ROTATIVAS

MODELO - CILÍNDRICA, ÁRVORE ARREDONDADA, ESFÉRICA, ÁRVORE PONTIAGUDA, OVAL, LABAREDA, CÔNICA.

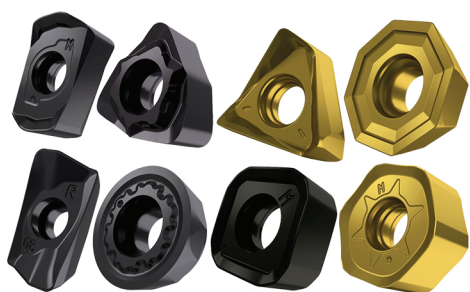

INSERTO DE FRESAMENTO

MODELO - ADMX, RCMT, SNGX, HNGX, BNGX, WNHX, TNGX, ODMT, ENTRE OUTROS MODELOS.



CABEÇOTES DE FRESAMENTO

MODELO - CANTO A 90°.

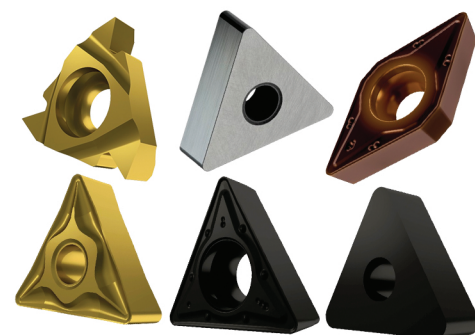

INSERTO DE TORNEAMENTO

MODELO - TNMG, TCMT, TNMA, TN, TNGA, DCMT, ENTRE OUTROS MODELOS.



CABEÇOTES DE TORNEAMENTO

MODELO - SDJCL, MTJNR, DTFNR, SER, ENTRE OUTROS MODELOS.



BROCAS DE CABEÇAS INTERCAMBIÁVEIS (HYDRA)

MODELO - (CABEÇA) AÇO (R950), AÇO INOXIDÁVEL (R960), FERRO FUNDIDO (R970)
(CORPO) 1.5XD | 3XD | 5XD | 8XD | 12XD.



BROCAS INDEXÁVEIS (T-MAX)

MODELO - 2XD, 3XD, 4XD, 5XD.
INSERTOS - XPET, SCET.



PINÇAS
MODELO - ER, DMC, SK, CONE HIDRÁULICO.

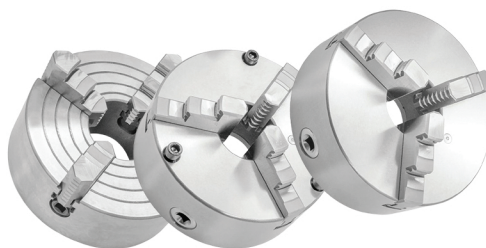

PLACAS
MODELO - MONOBLOCO, REVERSÍVEIS, INDEPENDENTES.



PONTOS ROTATIVOS
MODELO - COMPACT, HIGH SPEED, TUBO, SUPER CARGA.



DIVISOR UNIVERSAL
MODELO - BS-2.

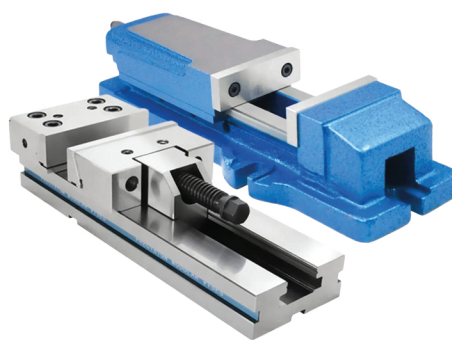

MORSA DE PRECISÃO MODELO - GTI 150, 200, 300, 400.
MORSA HIDRÁULICA MODELO - H-100, 125, 150, 200, 300.



LINHA COMPLETA DE CONES
MODELO - PORTA PINÇA, FRESA, WELDON, CONE MORSE.



ACESSÓRIOS DE FIXAÇÃO
MODELO - JOGO DE PRESILHAS, PORCAS, GRAMPO.



SUPORTE VDI
MODELO - RADIAL, AXIAL, BARRA WELDON, PORTA PINÇA.



BLOCO MAGNÉTICO
MODELO - SYT-150A, 200A.



ROSQUEADEIRA ELETRÔNICA COM BRAÇO ARTICULADO.
MODELO - M12, M16, M24, M36, M48.



MESA MAGNÉTICA
MODELO - MMC-2025, 2040, 3040, 3060.

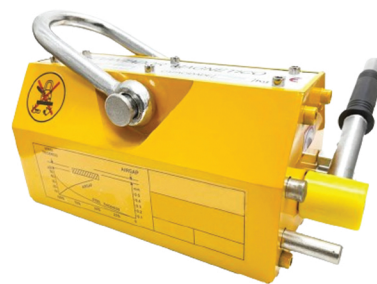

LEVANTADOR MAGNÉTICO
MODELO - LS1-0.2, 0.4, 0.6, 1, 2, 3.

DIGIMESS

INSTRUMENTOS DE PRECISÃO



PAQUÍMETRO UNIVERSAL

MODELO - RELÓGIO, GUIAS DE TITÂNIO, METAL DURO.



PAQUÍMETRO DIGITAL

MODELO - DÍGITOS GRANDES, FACES DE MEDIÇÃO, PROTEÇÃO IP54, IP65, IP67.



PAQUÍMETRO DE PROFUNDIDADE

MODELO - DIGITAL, SULCO DE PNEUS, COM GANCHO.



CALIBRADOR TRAÇADOR DE ALTURA

MODELO - DIGITAL, COM UMA E DUAS COLUNAS.



MICRÔMETRO EXTERNO

MODELO - DIGITAL, BATENTE INTERCAMBIÁVEIS.



MICRÔMETRO DE PROFUNDIDADE E COM 3 PONTAS

MODELO - DIGITAL, COM HASTES INTERCAMBIÁVEIS, TUBULARES.



MEDIDOR INTERNO

MODELO - DIGITAL, COM RELÓGIO E HASTES LONGAS.



RELÓGIO COMPARADOR E APALPADOR

MODELO - GRADUAÇÃO DE 0,01MM E 0,001MM



MESA DE MEDIÇÃO E DESEMPENO DE GRANITO

MODELO - AJUSTE FINO / CLASSE 0



COMPARADOR DE DIÂMETRO INTERNO (SÚBITO)

MODELO - BATENTES EM METAL DURO E CERÂMICA.

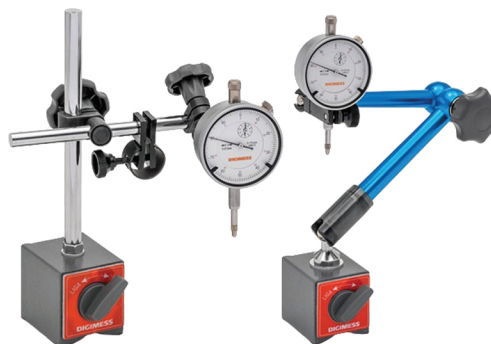

SUPORTE MAGNÉTICO

MODELO - AJUSTE FINO, ARTICULADO, FIXAÇÃO HIDRÁULICA.



NÍVEL LINEAR DE PRECISÃO E MEDIDOR DE INCLINAÇÃO

MODELO - BOLHA COM AJUSTE DE ZERAGEM | DIGITAL.



FRESA DE TOPO

MODELO - RETO, ESFÉRICO, TOROIDAL, DESBASTE.



FRESA RASGO "T" | FRESA WOODRUFF

MODELO - (RASGO T) HASTE PARALELA, CÔNICA. (WOODRUFF) DENTES RETOS, CRUZADOS.



FRESAS ANGULARES

MODELO - TOPO PARA MANDRIL, ÂNGULO DUPLO, PARA RASGO "RABO DE ANDORINHA".



FRESAS PERFIL CONSTANTE

MODELO - SEMI-CIRCULAR CONVEXA, MÓDULO, SEMI-CIRCULAR CÔNCAVA, CREMALHEIRA, ENGENHAGEM.



ALARGADOR PARA PINOS

MODELO - HASTE CILÍNDRICA, ARRASTE QUADRADO, CORTE À DIREITA.



ALARGADOR MANUAL PARA CONES

MODELO - HASTE CILÍNDRICA E ARRASTE QUADRADO, CORTE À DIREITA.



ALARGADOR MANUAL

MODELO - HASTE CILÍNDRICA, ENCAIXE QUADRADO, H7.



ALARGADOR MÁQUINA

MODELO - HASTE CILÍNDRICA, CORTE À DIREITA, H7.



ESCREADORES

MODELO - CILÍNDRICA 60°, CÔNICA 60°, 3 CORTES.

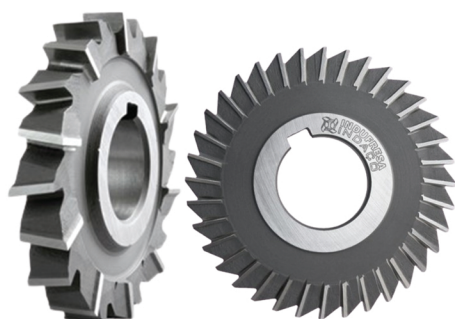

FRESAS CIRCULARES

MODELO - CORTE 3 LADOS E DENTADO EXTRA FINO.



FRESAS TOPO MANDRIL

MODELO - CHAVETA TRANSVERSAL, CHIPMASTER.



REBAIXADORES

MODELO - HASTE PARALELA, HASTE CÔNICA.

